

## BAGEL & ENGLISH MUFFIN SYSTEM

*Quality is "First and Formost"*

**GTS  
Bagger**



**SERVO OVERDRIVE OPTION**

**QUICK, SIMPLE CHANGEOVER**

**MAINTAINS PRODUCT QUALITY**

**GENTLE PRODUCT HANDLING**

**UP TO 65 BAGS PER MINUTE**

**PROVEN DEPENDABILITY**

## **GENTLE, DEPENDABLE BAGEL BAGGING**

The Formost Fuji Bagel / English Muffin System automatically bags product in a penny pack configuration. Specially designed paddles move product into the bags with a gentle hand-like motion. Our innovative bag opening system provides for greater tolerance of irregularities.

The system is durable and carefully engineered for trouble-free operation. It will save maintenance costs, too. All parts are readily accessible for easy cleaning and maintenance.

### **FORMOST FUJI CORPORATION**

19211 144<sup>th</sup> Avenue NE • Woodinville, WA 98072

Phone: 425-483-9090 • Fax: 425-486-5656 • email: [salesoffice@formostfuji.com](mailto:salesoffice@formostfuji.com)

**[www.formostfuji.com](http://www.formostfuji.com)**

**FORMOST FUJI**

# Gentle Reliable Bagging



The system meters, lanes, and groups the product for feeding to the chute.



The chute drops the product into an intermittent motion bucket conveyor which transfers the bagels / english muffins to the bagger.

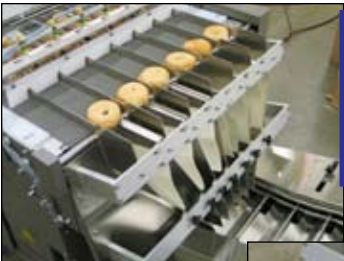

Transfer paddles gently push product through the openers and into the bag, creating a tight bag for best appearance.

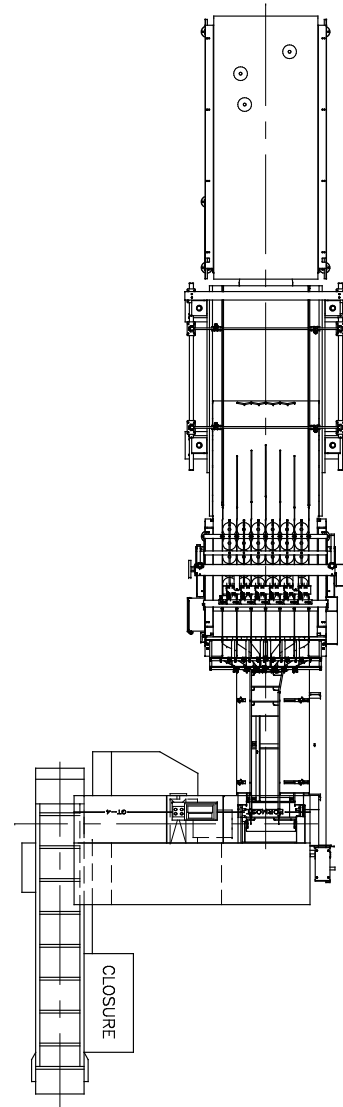

The Formost Fuji Bagel / English Muffin Bagging System is available in several configurations.

## Optional Features

- Automatic bag closure device
- Spare Parts Kit
- Rear infeed configuration
- Continuous, rotary or multi-wicket bag feed
- Product backlog monitoring system to maximize operation

GTS Bagel / English Muffin System					
Model	Length	Paddles	Paddle Spacing	Product Length	Bag Length
GTS-4	86"	4	40"	6" to 12"	20" max

These specifications may vary according to special applications. Specifications are based upon the latest information available at the time of publication. Formost reserves the right to make changes in materials, equipment and specifications without prior notice.

### FORMOST FUJI CORPORATION

19211 144<sup>th</sup> Avenue NE • Woodinville, WA 98072

Phone: 425-483-9090 • Fax: 425-486-5656 • email: salesoffice@formostfuji.com

[www.formostfuji.com](http://www.formostfuji.com)

