

FORMOST FUJI

FW3400 w/ **NEW!** Swing Arm Rotary End Seal



- INCREASED DWELL TIME
- INCREASED SEALING QUALITY AT HIGH SPEED
- EASILY CHANGES BETWEEN STD OR SWING ARM ROTARY END SEAL
- FLEXIBILITY for WIDE VARIETY OF PRODUCT / FILM TYPES

FW3400 w/ Swing Arm Rotary End Seal



MACHINERY SPECIFICATIONS

Machine Model		FW-3400/3700	FW-3410/3710
Operating Speed*		10-450 packs/min	10-300 packs/min
AC Infeed Drive Motor		300W	300W
Film Width		16.75" Max.	23.5" Max.
Film Cutoff Length*		1.5" - 17.5"	2.25" - 17.5"
Product Dimensions	Width	7" Max.	11" Max.
	Height	4" Max.	4" Max.
Machine Weight		1875 lbs.	1985 lbs.

Features

Heater for End seal is 15 degrees less than normal end seal.

Energy saving of approx. 9% on whole machine.

Comparative chart

Seal temp. and Speed (RD114, CP140mm)

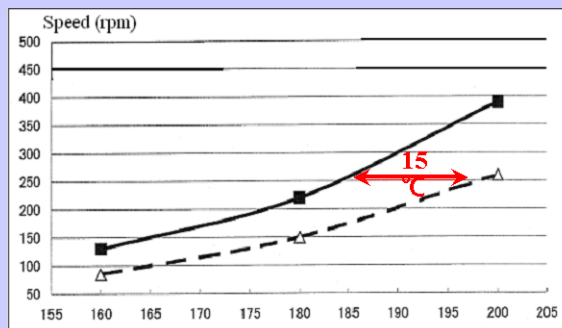

Swing seal type

Normal seal type

MACHINE LAYOUT

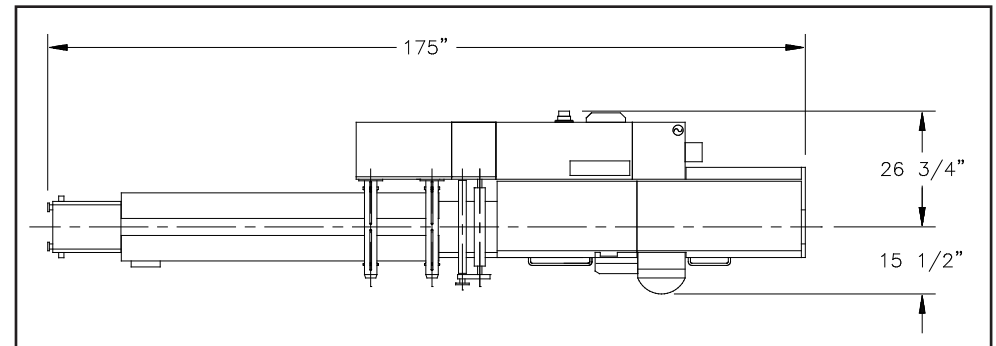

Formost Fuji Corporation

19211 144th Avenue NE • Woodinville, WA 98072

salesoffice@formostfuji.com

www.formostfuji.com